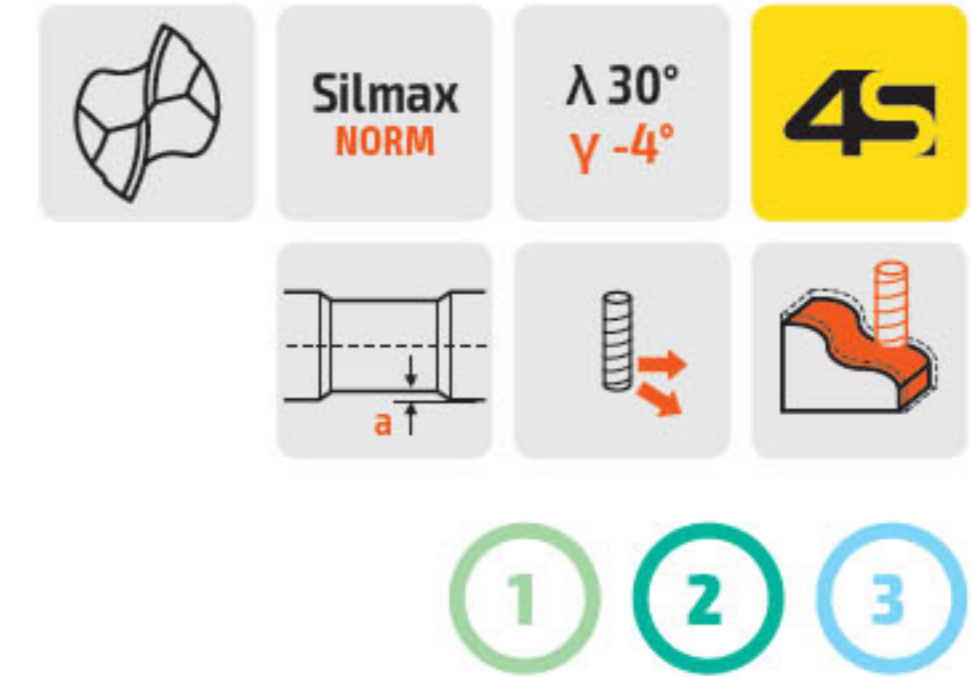
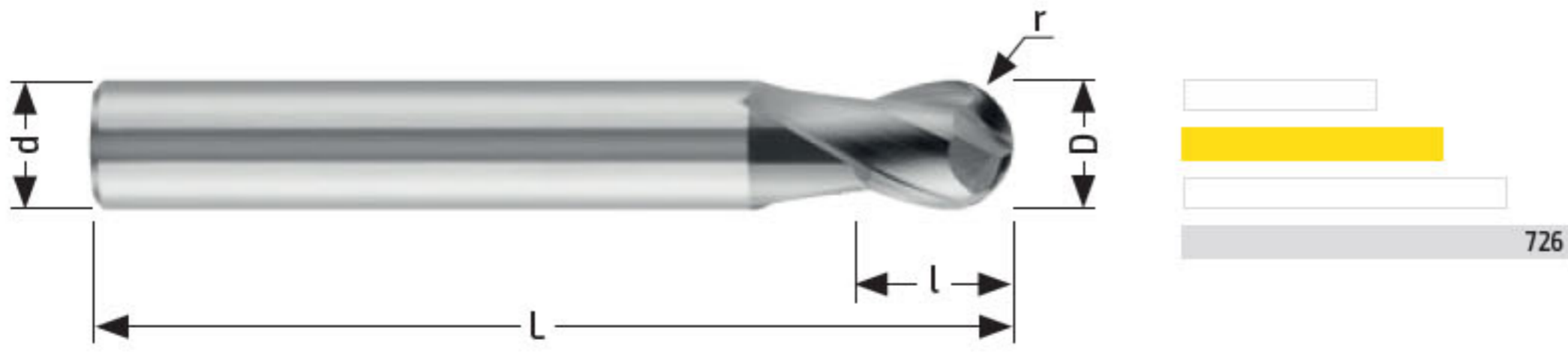

**NEW**  
**725**Fresa 2 taglienti serie normale semisferica per elevate asportazioni  
2 flute ball nose end mill for roughing

D	d h6	L	l ap	l1	a	r +/-0,01	Z	Balinit® Latuma	X-Hard
3,0	6	57	3,0	6,0	0,10	1,50	2	HMC725030	HMH725030
4,0	6	57	4,0	8,0	0,10	2,00	2	HMC725040	HMH725040
5,0	6	57	5,0	10,0	0,10	2,50	2	HMC725050	HMH725050
6,0	6	57	6,0	-	-	3,00	2	HMC725060	HMH725060
8,0	8	63	8,0	-	-	4,00	2	HMC725080	HMH725080
10,0	10	72	10,0	-	-	5,00	2	HMC725100	HMH725100
12,0	12	83	12,0	-	-	6,00	2	HMC725120	HMH725120

**1**  
Acciaio  
Steel**2**  
Ghise  
Cast  
Iron**3**  
Acciai  
Temprati  
Hardened  
Steel**4**  
Acciaio  
Inox  
Stainless  
Steel**5**  
Titanio  
Titanium**6**  
Leghe  
Leggere  
Light  
Alloys**7**  
PH  
Duplex**8**  
Superleghe  
Superalloys**9**  
Compositi  
Composite  
Materials**→ 16**  
Guida alla  
lettura  
Reading  
guide**→ 18**  
Legenda  
Legend